

MRY1500 – 3 Axis Milling Machine

60" stroke / 12" cross feed

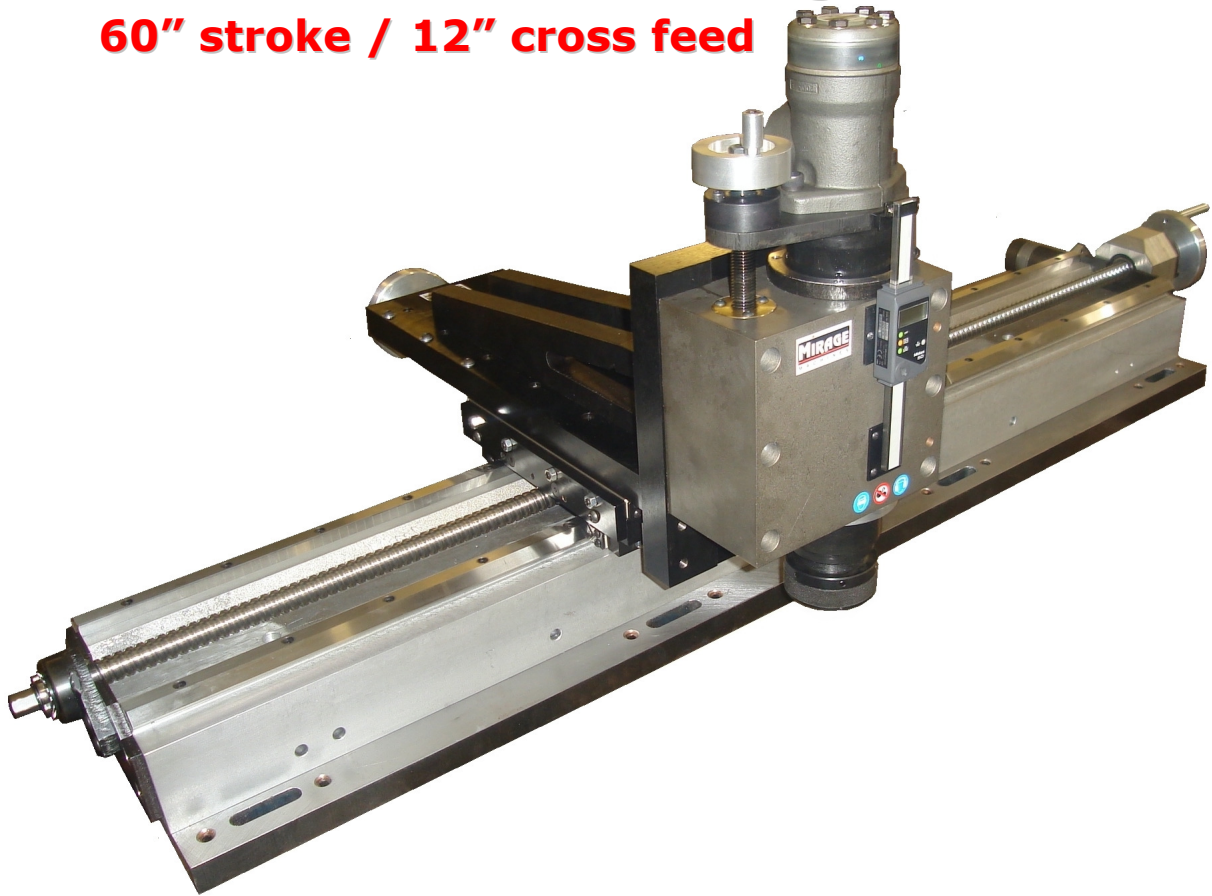

A 3 axis milling machine that is built for rigidity and accuracy suitable for all all general purpose in situ milling. Used on heat exchangers, pump and motor pads, steel mill stands, ship building, turbine split lines and many more applications.

- ***Induction hardened 'V' rails***
- ***Ball screw main axis auto feed***
- ***New fast set magnet mounting available***
- ***Mounts to our gantry mill***

Technical Details

RANGE		
Maximum stroke X (Main bed)	1500mm	60"
Maximum stroke Y (Cross feed)	305mm	12"
Maximum cutter diameter	254mm	10"
Maximum spindle down feed	80mm	3.15"
Drive - pneumatic	4.0 Hp	3.0 kw
Drive - hydraulic	5.0 Hp	3.7 kw
Spindle R.P.M	Min: 50	Max: 640
Feed - Pneumatic @ 90 p.s.i (6 bar)	1.5 Hp	1.11 Kw
Feed - hydraulic	2.2 Hp	1.64 Kw
Hydraulic supply @ 1050 psi (70 bar)	50 L/min	13 gal/min
Air Consumption / supply required	98 s.c.f.m	2.69 m3/m

FEED RATES		
Hand feed	10mm /rev	0.394"/rev
Auto feed standard motor supply	0 - 83mm/min	0 - 3.25"/min

WEIGHTS AND DIMENSIONS		
Machine weight	342 kgs	752 lbs
Shipping weight	417 Kgs	917 lbs

Shipping dimensions	L - 215cm - (85")	W- 35cm (14")	H- 35cm (14")
---------------------	-------------------	---------------	---------------

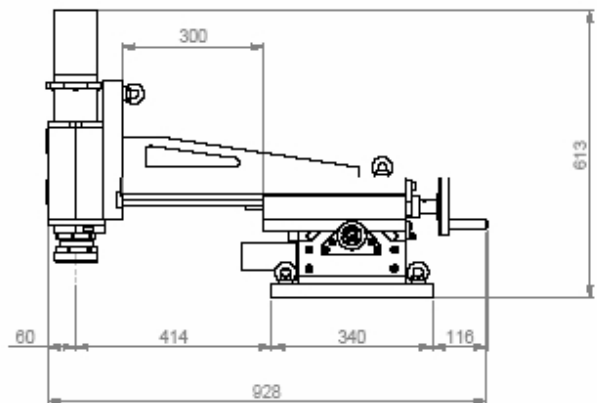
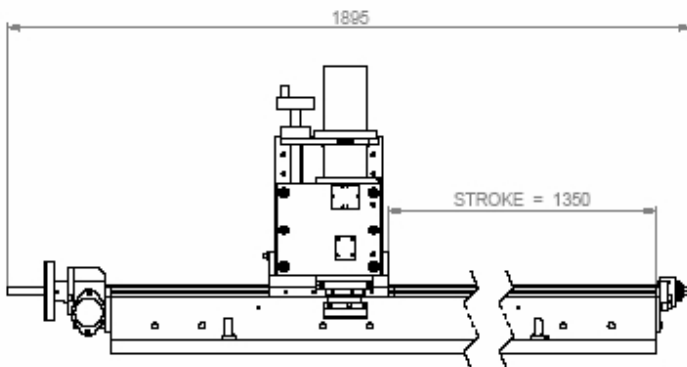

The machine is supplied complete with toolkit including air filter lubricator and hose connection (when required), all required bolts and storage / shipping box, CE certificate, Packing list and Manual



Pishgam Sanat Abzar Co.

Main office: No 372, 3rd floor, Abzar & Yaragh center, Imam Khomeini Street, Tehran, Iran
Tel. +982166712530, +982166713540

Manufacturing site: No. 3, 15 th St., Rezvanieh, Kamalshahr, Karaj, Iran. Tel.; +982634717900-4
info@pishgam.co.ir, www.pishgam.co.ir

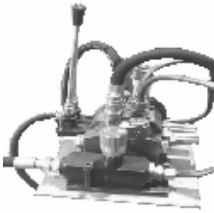

Optional accessories

 <p>MAG250 mounting magnets – High pull down mounting magnets for fast attachment to flat surfaces</p>	 <p>HYPP50-20-3ph 15Hp tandem hydraulic power pack 500 lpm / 20 lpm @ 70 bar – 380/440v 3 phase. Other configurations available</p>
 <p>DRO100 digital readout – 4" digital readout for accurately measuring spindle feed stroke and cut depth</p>	 <p>HYHK-10m twin hose kit - (feed and return) with flow controllers and valves to give independent speed and line control</p>

Pishgam Sanat Abzar Co.

Main office: No 372, 3rd floor, Abzar & Yaragh center, Imam Khomeini Street, Tehran, Iran
Tel. +982166712530, +982166713540

Manufacturing site: No. 3, 15 th St., Rezvanieh, Kamalshahr, Karaj, Iran. Tel.; +982634717900-4
info@pishgam.co.ir, www.pishgam.co.ir

