

## **MR500 – 2 Axis Milling Machine** **20" (500mm) stroke**



A milling rail that is built for rigidity yet with lightweight cast rail giving a 2 axis milling machine ideal for all general purpose in situ milling. Used on heat exchangers, pump and motor pads, steel mill stands, ship building, turbine split lines and many more applications.

- ***Induction hardened 'V' rails***
- ***Ball screw feed***
- ***Hand & Auto feed to main axis***
- ***Precision lightweight construction***
- ***Mounts directly to our gantry mill***

# Technical Details

RANGE		
Maximum stroke	508mm	20"
Maximum cutter diameter	254mm	10"
Maximum quill spindle down feed	80mm	3.15"
Drive - pneumatic	4.0 Hp	3.0 kw
Drive - hydraulic	5.0 Hp	3.7 kw
Spindle R.P.M	Min: 50	Max: 640
Feed - Pneumatic @ 90 p.s.i (6 bar)	1.5 Hp	1.11 Kw
Feed - Hydraulic	2.2 Hp	1.64 Kw
Hydraulic supply @ 1050 psi (70 bar)	50 L/min	13 gal/min
Air Consumption / supply required	98 s.c.f.m	2.69 m3/m

FEED RATES		
Hand feed	10mm /rev	0.394"/rev
Auto feed standard motor supply	0 - 83mm/min	0 - 3.25"/min

WEIGHTS AND DIMENSIONS		
Machine weight	110 kgs	242 lbs
Shipping weight	160 Kgs	352 lbs

Shipping dimensions	L - 120cm - (47")	W- 35cm (14")	H- 35cm (14")
---------------------	-------------------	---------------	---------------

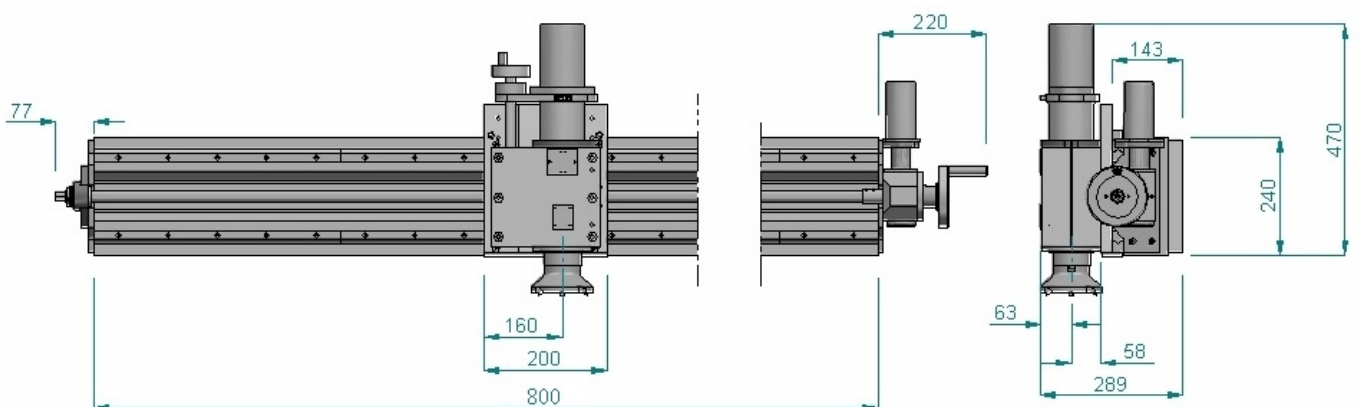

The machine is supplied complete with toolkit including air filter lubricator and hose connection (when required), all required bolts and storage / shipping box, CE certificate, Packing list and Manual

## Pishgam Sanat Abzar Co.

Main office: No 372, 3rd floor, Abzar & Yaragh center, Imam Khomeini Street, Tehran, Iran

Tel. +982166712530, +982166713540

Manufacturing site: No. 3, 15 th St., Rezvanieh, Kamalshahr, Karaj, Iran. Tel.; +982634717900-4

info@pishgam.co.ir, www.pishgam.co.ir

