

MR3000 – 2 Axis Milling Machine **120" (3048mm) stroke**



A milling rail that is built for rigidity yet with lightweight cast rail giving a 2 axis milling machine ideal for all general purpose in situ milling. Used on heat exchangers, pump and motor pads, steel mill stands, ship building, turbine split lines and many more applications.

- ***Induction hardened 'V' rails***
- ***Ball screw feed***
- ***Hand & Auto feed to main axis***
- ***Precision lightweight construction***
- ***Mounts directly to our gantry mill***

Technical Details

RANGE		
Maximum stroke	3048mm	120"
Maximum cutter diameter	254mm	10"
Maximum quill spindle down feed	80mm	3.15"
Drive - pneumatic	4.0 Hp	3.0 kw
Drive - hydraulic	5.0 Hp	3.7 kw
Spindle R.P.M	Min: 50	Max: 640
Feed - Pneumatic @ 90 p.s.i (6 bar)	1.5 Hp	1.11 Kw
Feed - Hydraulic	2.2 Hp	1.64 Kw
Hydraulic supply @ 1050 psi (70 bar)	50 L/min	13 gal/min
Air Consumption / supply required	98 s.c.f.m	2.69 m3/m

FEED RATES		
Hand feed	10mm /rev	0.394"/rev
Auto feed standard motor supply	0 - 83mm/min	0 - 3.25"/min

WEIGHTS AND DIMENSIONS			
Machine weight	329 kgs	724 lbs	
Shipping weight	508 Kgs	1118 lbs	
Shipping dimensions	L - 385cm (152")	W- 68cm (27")	H- 56cm (22")

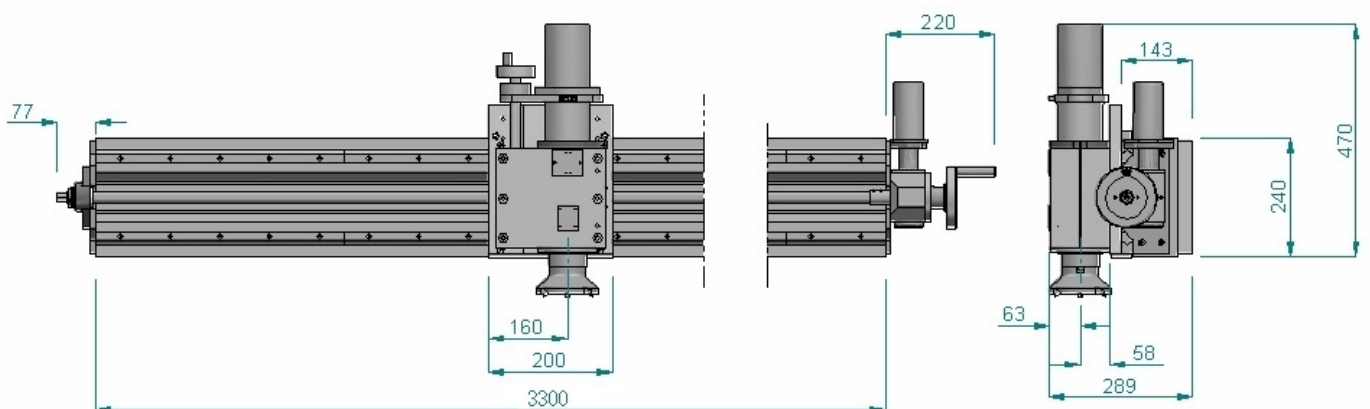

The machine is supplied complete with toolkit including air filter lubricator and hose connection (when required), all required bolts and storage / shipping box, CE certificate, Packing list and Manual

Pishgam Sanat Abzar Co.

Main office: No 372, 3rd floor, Abzar & Yaragh center, Imam Khomeini Street, Tehran, Iran
Tel. +982166712530, +982166713540

Manufacturing site: No. 3, 15 th St., Rezvanieh, Kamalshahr, Karaj, Iran. Tel.; +982634717900-4
info@pishgam.co.ir, www.pishgam.co.ir

