

LB100 Line boring machine **(6 – 36") diameters**



A precision heavy duty line boring machine for stern tubes, rudder bores, hinge pins, gearboxes, turbines and many more applications.

- ***Pneumatic or hydraulic helical drive***
High torque transfer with smooth power delivery
- ***Hollow hard chrome precision bar***
Reduced bar weight (sag) and assists laser alignment
- ***Infinitely variable auto feed***
Capable of cutting all materials
- ***Adjustable boring arms***
Quick set up and high torque transfer to the cutting tool
- ***Internal/external self aligning mounts***
Quick set up with spherical bearing out of alignment built in

Technical Details

RANGE		
Min. Boring diameter (Ø100mm bar)	152mm	6"
Maximum Boring diameter	915mm	36"
Standard boring bar length supplied	4000mm	157"
Maximum bar length	7500mm	296"
Bar R.P.M – standard	Min 5	130
Drive – Pneumatic @ 90 p.s.i (6 bar)	4.0 Hp	3.0 Kw
Feed – Pneumatic @ 90 p.s.i (6 bar)	1.5 Hp	1.11 Kw
Drive – hydraulic @ 1050 psi (70 bar)	5.0 Hp	3.7 Kw
Feed – hydraulic @ 1050 psi (70 bar)	2.2 Hp	1.64 Kw
Air Consumption / supply required	98 s.c.f.m	2.69 m3/m
Hydraulic supply required	50 L/min	13 gal/min

FEED RATES		
Boring Feed rate – infinitely variable	0 - 25mm/min	0 - 1.0"/min
Hand feed / revolution	2.0mm	0.078"

WEIGHTS AND DIMENSIONS		
Machine weight	416 kg	915 lbs
Shipping weight inc. standard bar	516 Kg	1135 lbs

Shipping dimensions	L - 100cm (40") L - 415cm (163")	W - 100cm (40") W - 30 (12")	H- 50m (20") H - 30cm (12")
---------------------	-------------------------------------	---------------------------------	--------------------------------

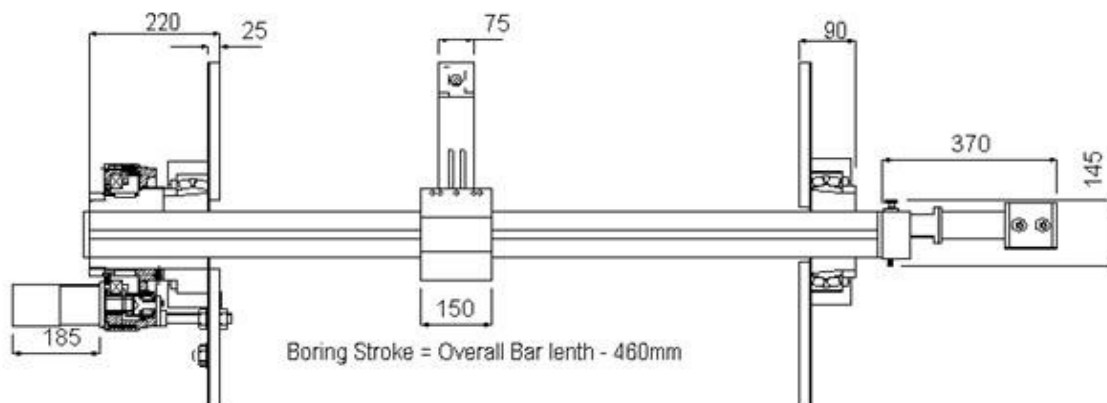

Standard supply:- toolkit, tools and inserts and toolbox, air filter lubricator and hose connection (where required), 2 off four leg mounting plates with self aligning bearings, adjustable arms, feed gearbox & motor, drive gearbox & motor, distributor, storage / shipping box, CE certificate, Packing list and Manual

Pishgam Sanat Abzar Co.

Main office: No 372, 3rd floor, Abzar & Yaragh center, Imam Khomeini Street, Tehran, Iran
Tel. +982166712530, +982166713540

Manufacturing site: No. 3, 15 th St., Rezvanieh, Kamalshahr, Karaj, Iran. Tel.; +982634717900-4
info@pishgam.co.ir, www.pishgam.co.ir



Component selection

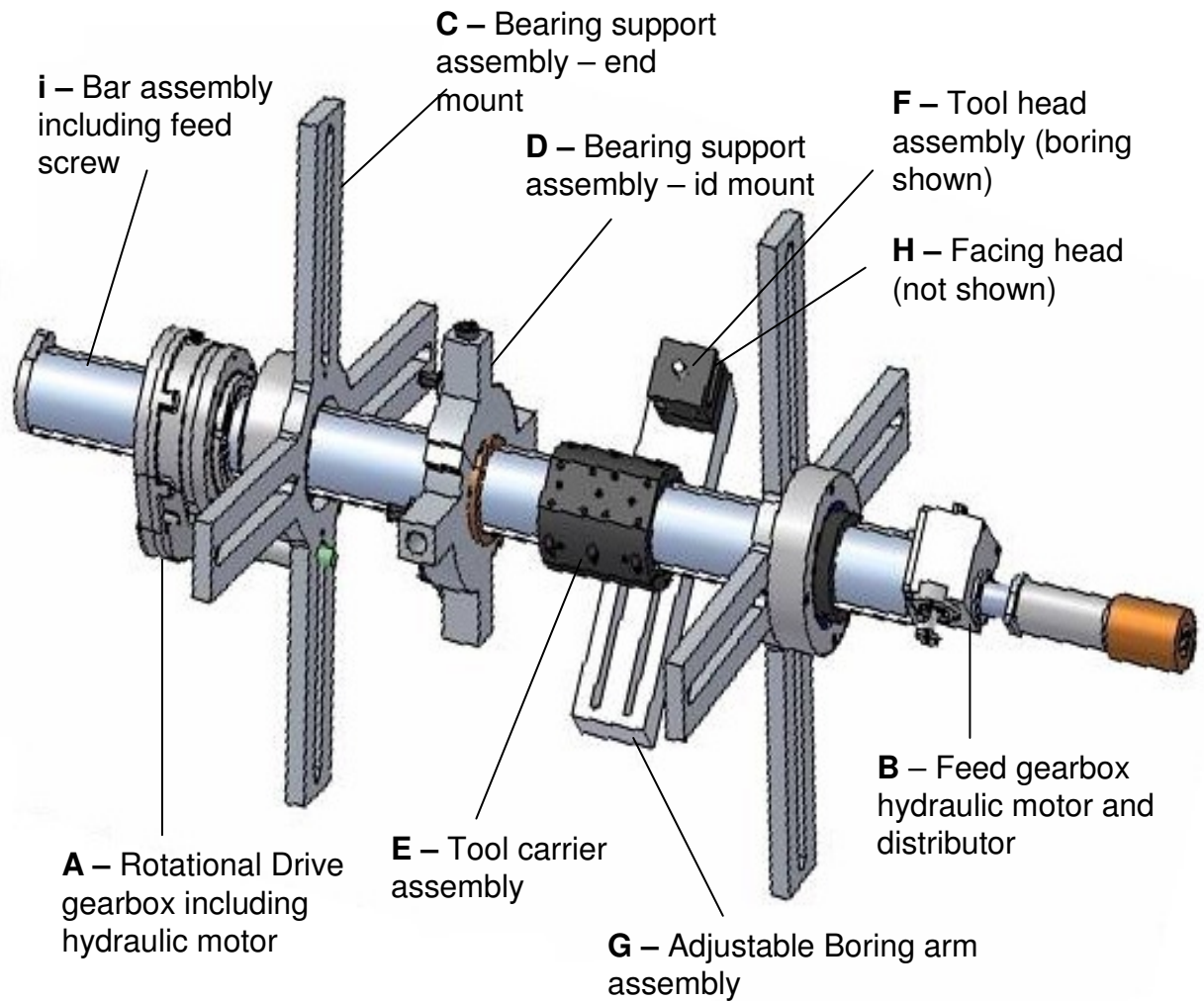

	Part No.	Description
A	LB100-1	Rotational Drive & hydraulic motor
B	LB100- 2	Feed gearbox , hydraulic motor & distributor
C	LB100-3	(12 - 32") End mount bearing support
D	LB100-4*	(18 - 36") ID mount bearing support
E	LB100-5	Tool carrier assembly
F	LB100-6	(6 -15") Tool post assembly & spacers
G	LB100-7	(15 - 36") Adjustable boring arm set
H	LB100-8*	4" stroke facing head assembly & striker
i	LB100-9-3	Boring bar / feed screw assembly (suffix length m)

Items marked * are optional all other items are standard supply